

# Operating Instructions

## Industrial Color Camera GP-KS1000



(Lens and Cable: option)

# Panasonic®

Before attempting to connect or operate this product, please read these instructions completely.

# CONTENTS

PREFACE .....	1
FEATURES .....	1
PRECAUTIONS .....	2
SYSTEM BLOCK DIAGRAM .....	3
MAJOR OPERATING CONTROLS AND THEIR FUNCTIONS .....	3
PREPARATIONS .....	6
INSTALLATIONS .....	7
CONNECTIONS.....	8
USER FILE SETTING .....	9
PREVENTION OF BLOOMING AND SMEAR .....	10
SPECIFICATIONS .....	11
OPTIONAL ACCESSORIES .....	11

**Caution:**

Before attempting to connect or operate this product, please read the label on the bottom.



**CAUTION**

RISK OF ELECTRIC SHOCK  
DO NOT OPEN



**CAUTION:**  
TO REDUCE THE RISK OF ELECTRIC SHOCK, DO NOT REMOVE COVER (OR BACK). NO USER SERVICEABLE PARTS INSIDE.  
REFER SERVICING TO QUALIFIED SERVICE PERSONNEL.



SA 1965

The lightning flash with arrowhead symbol, within an equilateral triangle, is intended to alert the user to the presence of uninsulated "dangerous voltage" within the product's enclosure that may be of sufficient magnitude to constitute a risk of electric shock to persons.



SA 1966

The exclamation point within an equilateral triangle is intended to alert the user to the presence of important operating and maintenance (servicing) instructions in the literature accompanying the appliance.

For U.S.A.

**Warning:**

This equipment generates and uses radio frequency energy and if not installed and used properly, i.e., in strict accordance with the instruction manual, may cause harmful interference to radio communications. It has been tested and found to comply with the limits for a Class A computing device pursuant to Subpart J of Part 15 of FCC Rules, which are designed to provide reasonable protection against such interference when operated in a commercial environment.

The serial number of this product may be found on the bottom of the unit.  
You should note the serial number of this unit in the space provided and retain this book as a permanent record of your purchase to aid identification in the event of theft.

Model No. \_\_\_\_\_

Serial No. \_\_\_\_\_

**WARNING:**

TO PREVENT FIRE OR ELECTRIC SHOCK HAZARD, DO NOT EXPOSE THIS APPLIANCE TO RAIN OR MOISTURE.

## PREFACE

The Panasonic's Industrial Digital Signal Processing Color Camera GP-KS1000 overcomes space limitations that have complicated many video applications. Weight of only 18 g (0.04 lbs), this remarkably compact industrial camera measures only two-thirds of an inch in diameter and less than two inches in length. This camera can be extended up to 10-meter (33 feet) away, using an optional 10-meter (33-foot) cable. With the 900,000-element, 1/2-inch CCD pick-up device, horizontal resolution is more than 560 lines, and signal-to-noise ratio is 54 dB. The Gain Selection switch at AGC lets you obtain clear, high-quality color images in light as low as 5 lx (0.5 footcandle) at F1.4.

## FEATURES

1. 1/2 inch Interline Transfer CCD image sensor with 830 (H) x 970(V) pixels.
2. 560 lines of horizontal resolution.
3. 5 lx (0.5 footcandle) at F1.4 of minimum scene illumination.
4. 54 dB of signal to noise ratio.
5. Selectable Auto Tracing White Balance (ATW), Auto White Balance Control (AWC) or Manual White Balance Control.
6. Setting gain AGC or shutter AUTO position enable to control the video level.
7. DC 12V operation
8. 10-meter (33-feet) of maximum cable length between camera head and camera control unit with optional camera cable.
9. Gen-lock capability.
10. Built-in full color bar generator.
11. RGB and S-Video Outputs are provided.
12. The electronic shutter speed is variable as follows: Auto (the speed is changed automatically) and seven fixed speeds.
13. Four positions to store the memorized settings which can be desirably changed (aperture level, chroma gain, etc.) by using the User switch according to the situation.

## PRECAUTIONS

- Do not attempt to disassemble the camera or the camera control unit.  
To prevent electric shock, do not remove screws or cover. There are no user-serviceable parts inside. Refer servicing to qualified service personnel.
- Do not expose the camera or camera control unit to rain or moisture, or do not try to operate it in wet areas. Do take immediate action if ever the camera or camera control unit do become wet. Turn power off and refer servicing to qualified service personnel.  
Moisture can damage the camera and camera control unit and also create the danger of electric shock.
- Ambient Temperature range  
Do not install the camera in the place where the temperature is beyond  $-10^{\circ}\text{C}$  -  $+40^{\circ}\text{C}$  ( $14^{\circ}\text{F}$  -  $104^{\circ}\text{F}$ ).
- Never crush or pinch the camera cable.  
Do not bend the camera cable into a curve whose radius is too small.
- Never face the camera toward the sun whether the camera is in use or not.  
Do use caution when operating the camera in the vicinity of spot lights or other lights and light reflecting objects.
- How to take care of this camera and the camera control unit.  
After turning OFF the DC Power ON/OFF Switch, clean them with a dry cloth. If it is difficult to remove the dirt or dust, clean them up with a cloth applied the neutral cleanser.  
Use the lens cleaning tissue paper(may be available at your local camera store) for lens cleaning.
- Connect this to a DC12V, CLASS 2 Power supply only.
- After using the camera, turn OFF the DC Power ON/OFF Switch and put the lens cap on the camera head.
- Connect together only the camera head and the camera control unit which are packed in the same box (a pair). Otherwise it may cause a improper operation.
- Every necessary procedures with regard to install this product should be made by qualified service personnel or system installers.

**Caution:**

Connecting or disconnecting camera cable to/from the camera control unit or the camera must be done after turning OFF the DC Power ON/OFF Switch. Otherwise, the camera head may be damaged.

# SYSTEM BLOCK DIAGRAM

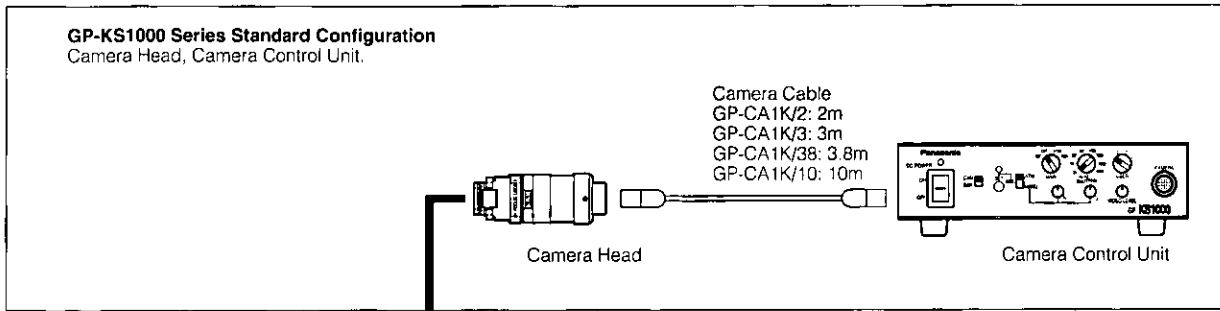

## Optional Accessories

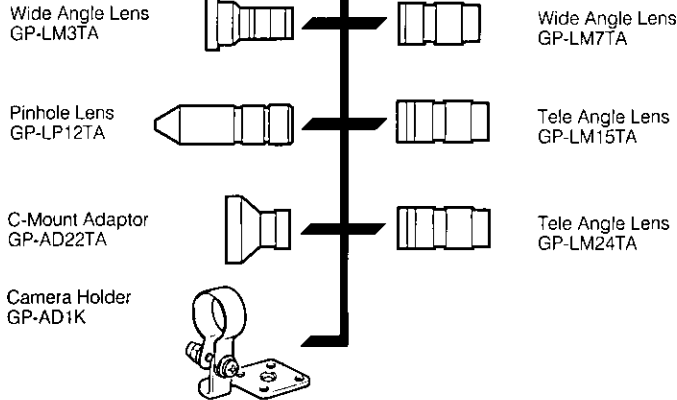

# MAJOR OPERATING CONTROLS AND THEIR FUNCTIONS

## Camera Control Unit

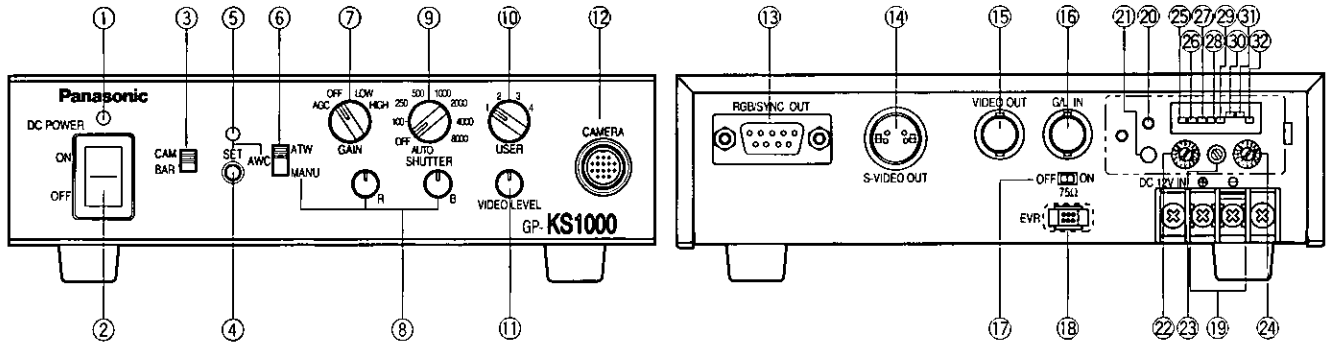

## Camera Head with Optional Lens

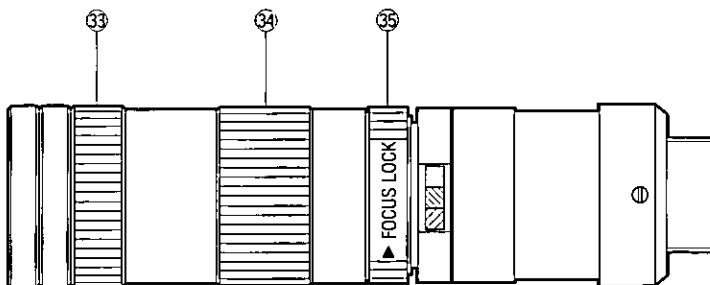

## Camera Control Unit

### ① Power Indicator

The indicator lights up red when the DC power On/Off switch ② is turned on.

### ② DC Power On/Off Switch (DC POWER, ON/OFF)

This switch turns on and off the power of this unit and power supply for the camera.

### ③ Camera/Color Bar Selection Switch (CAM/BAR)

This switch is used to switch either the video signal or the full color bar signal which is output from the Video Output Connector (VIDEO OUT), Y/C (S-VIDEO OUT) Output Connector or RGB (D-SUB, 9-pin) Output Connector.

**CAM:** The video signal produced by the camera is output.

**BAR:** The full color bar signal is output. Set the switch to bar position when making video monitor adjustments and recording the color bar signal.

### ④ AWC Set Button (AWC SET)

The white balance can be set by pressing this button when the White Balance Selection Switch ⑥ is set to the AWC position.

### ⑤ White Balance Indicator

This indicator blinks while the white balance is being automatically set. This indicator lights continuously when the white balance is set improperly. In this case, carry out the auto white balance setting procedure.

### ⑥ White Balance Selection Switch (ATW/AWC/MANU)

**ATW:** In this Auto-Tracing White Balance (ATW) position, the color temperature of the illuminant is continuously monitored and the white balance of the camera is automatically set.

**AWC:** This switch is used to set the Auto White Balance (AWC) together with AWC Set Button ④.

**Note:** When the White balance Offset On/Off Switch ⑳ is turned on, the fine adjustment for R/B Gain Controls ⑧ is available after completing the white balance setting.

**MANU:** The R/B gain of the white balance can be adjusted manually by means of the R/B Gain Controls ⑧.

### ⑦ Gain Selection Switch (AGC / OFF / LOW / HIGH)

This switch is used to select the gain of the video amplifier as follows:

Position of the Switch		Gain
AGC		Maximum +18 dB
MANU	HIGH	+18 dB
	LOW	+9 dB
	OFF	0 dB

### ⑧ R / B Gain Controls (R/B)

These controls are used to adjust the R and B gain of the white balance.

These controls are available only when the White Balance Offset On/Off Switch ⑳ is turned on in the AWC or MANU mode.

### ⑨ Electronic Shutter Switch (AUTO, OFF, 1/100, 1/250, 1/500, 1/1000, 1/2000, 1/4000, 1/8000)

**AUTO:** In this position, the electronic shutter speed is changed automatically to obtain the proper video level according to the light condition. Target value of the shutter speed can be adjusted manually by using Video Level Control ⑩.

**OFF:** In this position, the electronic shutter is turned off.

**1/100-1/8000:** Seven fixed electronic shutter speeds are available from 1/100 -1/8000.

### ⑩ User Switch (USER)

- When AWC setting is made by pressing AWC Set Button ④, AWC setting is stored on the selected position of this switch.

The stored AWC settings are only available when the White Balance Selection Switch ⑥ is set at AWC.

- User File Setting, which is desirably memorized by User File Set Switch ㉑, User File Item Switch ㉒, User File Adjust Control ㉓, and User File Select Switch ㉔ are available up to four ways.

Refer User File Setting on page 9 for more details.

### ⑪ Video Level Control (VIDEO LEVEL)

The standard video level can be adjusted when the Gain Selection Switch ⑦ is set at AGC or the Electronic Shutter Switch ⑨ is set at AUTO.

### ⑫ Camera Cable Connector (CAMERA)

This 20-pin connector is used for connection of the optional camera cable.

**Caution:** Connecting or disconnecting the camera cable must be done after turning off by the DC Power On/Off Switch ②.

### ⑬ RGB/SYNC Output Connector (D-SUB, 9-PIN) (RGB/SYNC OUT)

The red, green, blue, sync and composite video signals are provided at this connector.

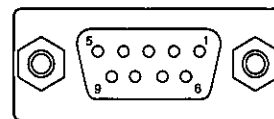

RGB/SYNC OUT (D-SUB, 9-pin)

Pin No.	Description
1	Ground (GND)
2	Ground (GND)
3	Red (R) Output (0.7 V [p-p] /75 Ω)
4	Green (G) Output (0.7 V [p-p] /75 Ω)
5	Blue (B) Output (0.7 V [p-p] /75 Ω)
6	Composite Video Output (1.0 V [p-p] /75 Ω)
7	Sync (SYNC) Output (0.3 V [p-p] /75 Ω)
8	Ground (GND)
9	Ground (GND)

**14 S-Video Output Connector (S-VIDEO OUT)**

The luminance (Y) and chroma (C) signals for S-VHS VCR or monitor are provided at this connector.

Pin Configuration

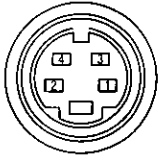

Pin No.	Description
1	Y Ground (GND)
2	C Ground (GND)
3	Y Signal Output: 0.714 V [p-p] (Y level / 75 Ω)
4	C Signal Output: 0.286 V [p-p] (burst level / 75 Ω)

**15 Video Output Connector (VIDEO OUT)**

A 1.0 V[p-p] composite video signal is provided at this connector.

**16 Gen-lock Input Connector (G/L IN)**

The color video signal of the camera is automatically synchronized to the gen-lock signal (Composite Signal, Black Burst Signal or Video Sync) when either signal is supplied to this connector.

**Caution:** If the gen-lock signal is jittery as in the case of a VCR playback picture, the camera can not be synchronized properly.

**17 Gen-lock Video 75 ohms Termination On/Off Switch (75 Ω ON/OFF)**

When looping through the gen-lock video signal with BNC "T" Adaptor, set this switch to the OFF position. When not looping through, set this switch to the ON position.

**18 EVR Adjustment Connector**

This connector is used to connect with the EVR. Usually use with rubber capped on the connector.

**19 DC 12V Input Terminals (DC 12V IN)**

These terminals accept an external DC source supplying nominal power of 12V, 0.7A -1A.

**CAUTION:** CONNECT THIS TO A DC 12V CLASS 2 POWER SUPPLY ONLY.

**Caution**

To prevent fire or electric shock hazard, the UL listed wire VW-1 style 1007 should be used for the cable for DC 12V Input Terminal.

**20 User File Set Indicator**

This indicator show the setting steps of the User File Set as follows:

Setting	Indicator
is on process	Blinks
is completed	Goes off after blinking
is incomplete	Lights up

**21 User File Set Switch**

This switch is used to change and memorize the setting of User File Set Function.

**22 User File Item Switch**

This switch is used to select the desired item to change as follows:

Refer User File Setting on page 9 for more details.

**23 User File Adjust Control**

This control is used to adjust the desired item to change.

**24 User File Select Switch**

This switch is used to select the setting of SC Coarse (item No.1) or the sensing zone (item No.7).

**25 User File Set On/Off Switch  on/off**

This switch is used to activate the User File Setting Function. When the switch is set to ON, User File Item Switch 22, User File adjust control 23, and User File select Switch 24 are available to set the User File Settings Function.

**26 This switch is preset at the factory.  on/off**

Fix this switch to the off position.

**27 PEAK / AVE Switch  on/off**

This switch is used to select PEAK or AVERAGE detection of the AGC and ELC. Turning this switch on selects PEAK detection, and turning this switch off selects AVERAGE detection. The target video level can be changed by using Video Level Control 11 on the front panel.

Usually, turn off this switch.

**28 White Balance Offset On/Off Switch  on/off**

By turning on this switch, the white balance offset in the AWC can be adjusted fine by using the R/B Gain Controls 8.

Usually, turn on this switch.

**29 This switch is preset at the factory.  on/off**

Fix this switch to the on position.

**30 This switch is preset at the factory.  on/off**

Fix this switch to the off position.

**31/32 Cable Switch  on/off**

These switches are provided for the optional cables. Set the switches according to the length of the optional cables as follows:

Cable Switch 31	Cable Switch 32	Cable (length)
OFF	OFF	GP-CA1K/2 (2m)
ON	OFF	GP-CA1K/3 (3m)
OFF	ON	GP-CA1K/38 (3.8m)
ON	ON	GP-CA1K/10 (10m)

**Note :** Make sure that the settings of switches are correct for the cable length.

Otherwise normal video is not obtained.

## Camera Head with Optional Lens

### ③ Manual Iris Control Ring

The ring is used to adjust the lens iris manually.

### ④ Focus Ring

This ring is used to adjust the focus of the picture. To adjust the focus, loosen the Focus Lock Ring ⑤ by rotating it clockwise (viewed from the front of the camera) and turn the Focus Ring until picture becomes the best resolution. Secure the Focus Ring by rotating the Focus Lock Ring ⑤ counterclockwise.

### ⑤ Focus Lock Ring

This ring is used to secure the Focus Ring ④.

## PREPARATIONS

**Caution:** Keep the DC Power ON/OFF Switch of the camera control unit in the OFF position through the installation.

### Camera Head with GP-LM3TA, GP-LM7TA, GP-LM15TA, GP-LM24TA or GP-LP12TA

1. Remove the front cap of the camera and confirm that the surface of the optical filter of the camera head is clean.

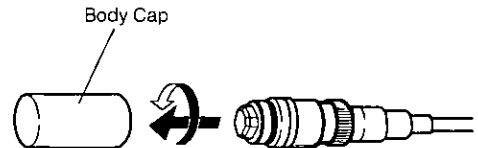

If the surface of the optical filter is dirty or dusts are on it, clean it up with a blower brush which is for film camera lenses (may be available at your local camera store) or supplied lens cleaning tissue.

2. Rotate the focus lock ring fully clockwise. Mount the Pinhole Lens, Wide-angle Lens or Tele-angle Lens to the camera by rotating it clockwise slowly.

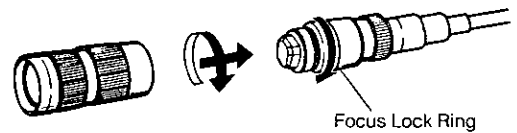



## Camera Head with GP-AD22TA and optional C-mount lens

1. Remove the front cap of the camera head and confirm that the surface of the optical filter of the camera head is clean.

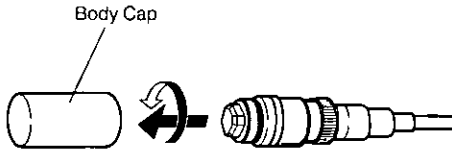

If the surface of the optical filter is dirty or dusts are on it, clean it up with a blower brush which is for film camera lenses (may be available at your local camera store) or supplied lens cleaning tissue.

2. Attach the optional C-mount lens to the C-mount Adaptor GP-AD22TA by rotating it clockwise.

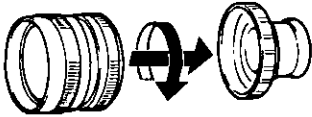

3. Rotate the focus lock ring fully. Mount the lens and C-mount adaptor by rotating them clockwise slowly.

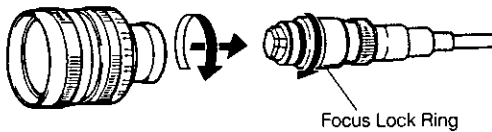

**Caution:** If the optional C-mount lens size exceeds 50mm (2") in diameter, 70mm (2-3/4") in length and 300g (0.66 lbs) in weight, both the camera and lens should be secured.

## INSTALLATIONS

The camera head can be installed on the ceiling, wall or etc. using the threaded 1/4"-20 UNC screw hole of the camera holder (optional accessory).

1. Loosen a screw of the camera holder until it is stopped and insert the camera head into the camera holder shown below.

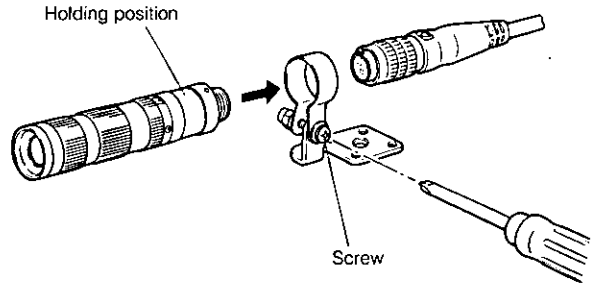

2. Adjust the tilt angle and rotation of the camera head and secure the camera and camera holder by tightening the screw.

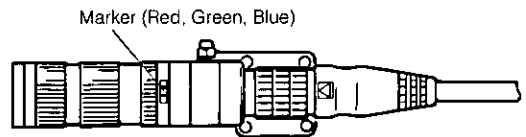
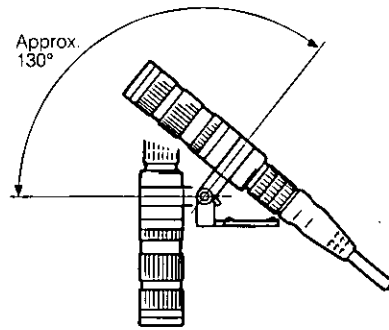

3. Install the camera with camera holder onto the tripod or other mounting bracket.

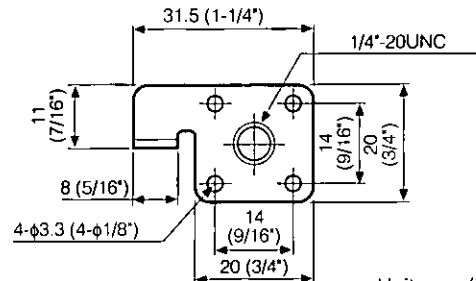

Unit: mm (inches)

**Caution:** If the optional C-mount lens size exceeds 50mm (2") in diameter, 70mm (2-3/4") in length and 300g (0.66 lbs) in weight, both the camera and lens should be secured.

# CONNECTIONS

## CAUTIONS:

- Keep the DC Power ON / OFF Switch in the OFF position until all connections have been properly made.
- Connect the camera head and camera control unit which are packed in the same box (a pair) otherwise it would be cause improper operation.

## Internal Sync Operation

1. Connect the camera cable between the camera head and the camera control unit.
2. Connect the coaxial cable with BNC connectors between the Video Output Connector of the camera control unit and the video monitor or VCR.

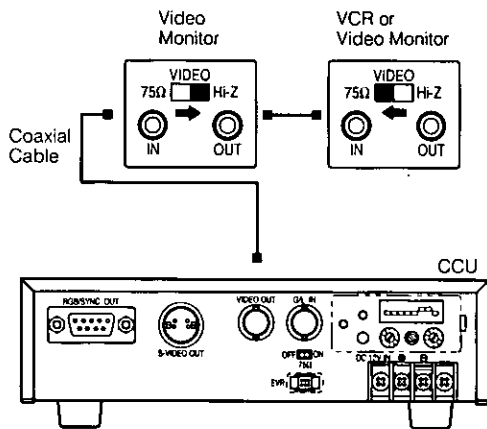

3. Connect the power cable between the DC 12V Input Terminals and the 12V DC power supply unit (obtained locally).
- Calculation method of maximum cable length between camera control unit and the power supply unit is as follows:

$$10.5V DC < VA - (R \times 0.42 \times L) < 16V DC$$

L: Cable length (meter)

R: Resistance of copper wire (ohms / meter)

VA: DC output voltage of power supply unit

$$L \text{ standard} = VA - 12 / 0.42 \times R \text{ (meter)}$$

$$L \text{ minimum} = VA - 16 / 0.42 \times R \text{ (meter)}$$

$$L \text{ maximum} = VA - 10.5 / 0.42 \times R \text{ (meter)}$$

## CAUTION

CONNECT THIS TO A 12V DC CLASS 2 POWER SUPPLY ONLY.

## Caution

To prevent fire or electric shock hazard, the UL listed wire VW-1, style 1007 should be used for the cable for 12V DC Input Terminals.

## Gen - lock Operation

1. Connect the camera cable between the camera head and the camera control unit.
2. Connect the coaxial cable with BNC connectors between the Video Output Connector of the camera control unit and the Video Input Connector of Special Effects Generator (SEG), and between the G/L Input Connector of the camera control unit.

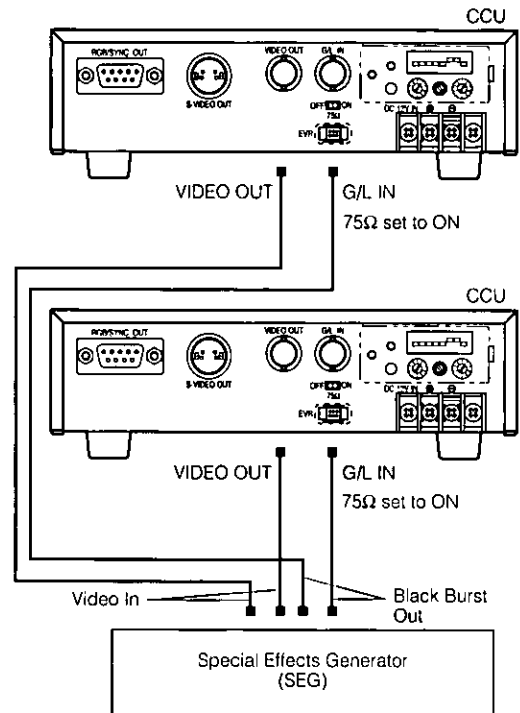

3. Connect the power cable between the DC 12V Input Terminals and the 12V DC power supply unit (obtained locally).

## CAUTION

CONNECT THIS TO A 12V DC CLASS 2 POWER SUPPLY ONLY.

## Caution

To prevent fire or electric shock hazard, the UL listed wire VW - 1, style 1007 should be used for the cable for 12V DC Input Terminals.

# USER FILE SETTING

It is available to use the user preference stored by selecting user switch.

AGC/ELC Sensing Zone (Item No. 7)

1. Remove the switch cover on the rear of the camera control unit by removing a screw.

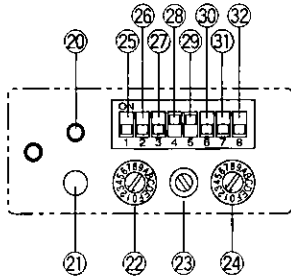
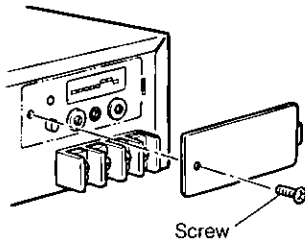

2. Select desired user file (1 - 4) by rotating the User Switch ⑩.
3. Set User File Set On/Off Switch ⑫ on the rear panel to ON.
4. Select desired item to change by rotating the User File Item Switch ⑭ .  
The item number indicates item shown below.

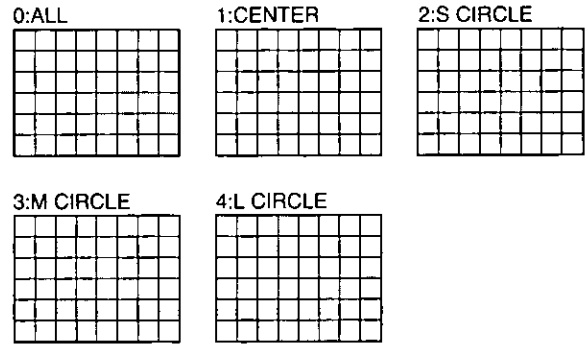

**Note:** Item 1 and 2 settings are not stored at each user file distinctively.

5. Select or adjust the level of the desired item by the User File Select Switch ⑭ or User File Adjust Control ⑮.
6. Press User File Set Switch ⑯ to memorize the set level.
7. Repeat the above procedures 4 to 6 to set the other items.
8. After all the settings finished, set User File Set On/Off Switch ⑫ to off.
9. Place the switch cover onto the rear of the camera control unit and tighten with a removed screw.

Item No.	Item	Adjust control ⑮	Select switch ⑭
0	G/L H Phase	Valid	Invalid
1	G/L SC Coarse/Phase	Valid	Valid 0:0°
			1:90°
			2:180°
			3:270°
2	DTL Level	Valid	Invalid
3	Chroma Gain	Valid	Invalid
4	Color Matrix (R-G)	Valid	Invalid
5	Color Matrix (B-G)	Valid	Invalid
6	Pedestal Level	Valid	Invalid
7	AGC/ELC Sensing Zone	Invalid	0: ALL
			1: CENTER
			2: S CIRCLE
			3: M CIRCLE
			4: L CIRCLE
8	(NC)		
9	Reset All Settings	Invalid	Invalid

### Caution

Do not set User File Item Switch ⑭ to the position, A to F. If the setting (A to F) is made, select both User File Item Switch ⑭ and User File Select Switch ⑭ to the position F, then press User File Set Switch ⑯.

## PREVENTION OF BLOOMING AND SMEAR

When the camera is aimed towards spotlights or other bright lights or light reflecting objects, smear or blooming may appear.

Therefore the camera should be carefully in the vicinity of extremely bright objects to avoid smear or blooming.

If the camera is aimed at the sun or very bright light, such as laser beam, for a long period of time, the CCD image sensor may be burned in and blemishes (white or black dots) appears on the monitor screen.

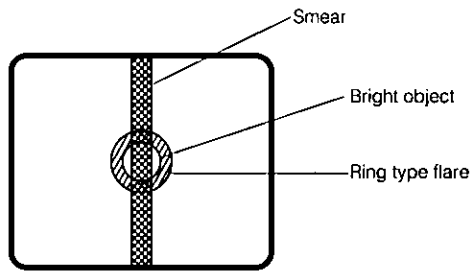

## SPECIFICATIONS

Image Sensor :	1 / 2" interline transfer (IT) CCD image sensor	
Pixels :	830 (Horizontal) x 970 (Vertical)	
Scanning Standard :	525 lines, 60 fields, 30 frames	
	Synchronizing System : Internal or External (Gen-lock), automatically switchable NTSC standard	
	External (Gen-lock) Input : VBS / VS is selectable	
Video Outputs :	Video Output : BNC Connector x 1	
	1.0 V [p-p] NTSC composite / 75 $\Omega$	
	Y/C (S-VIDEO) Output : S-VIDEO Connector x 1	
	0.714 V [p-p] Luminance level (Y) / 75 $\Omega$ (S-VIDEO connector)	
	0.286 V [p-p] Burst level (C) / 75 $\Omega$ (S-VIDEO connector)	
	RGB / SYNC Output : D-SUB 9-pin Connectors x 1	
	R / G / B : 0.7 V [p-p] each / 75 $\Omega$	
	SYNC : 0.3 V [p-p] / 75 $\Omega$ selectable	
Required Illumination :	2000 lx at F5.6, 3200K	
Minimum Illumination :	5 lx (0.5 fc) at F1.4 with +18dB gain, 30 IRE level	
Signal to Noise Ratio :	54 dB (Typical luminance) without aperture and gamma	
Horizontal Resolution :	560 lines at center (Y signal)	
White Balance :	ATW (Automatic Tracing White Balance Control), AWC (Automatic White Balance Control) and Manual	
Color Bar :	Built-in full color bar	
Electronic Shutter :	Selectable : AUTO, 1/100, 1/250, 1/500, 1/1000, 1/2000, 1/4000 and 1/8000	
Gain Selection ::	AGC and Gain Up (OFF / LOW / HIGH)	
Switches :	Power On/Off (POWER), Camera / Color Bar Selection (CAM / BAR), Gain Selection (AGC / OFF / LOW / HIGH (0 / +9 / +18dB)), Auto White Balance Set (AWC SET), White Balance Selection (ATW / AWC / MANU), Shutter Speed Selection, User File Selection (1 / 2 / 3 / 4)	
Controls :	R gain, B gain and VIDEO Level	
Lens Mount :	Special Mount	
Power Source :	12V DC, 700 mA	
Ambient Operating Temperature :	-10°C - +40°C	
Ambient Operating Humidity :	30 %- 90%	
Dimensions :	Camera Head :	17 mm (Diameter) x 42 mm (11/16" x 1-5/8")
	(Excluding Lens and Body Cap)	
	Camera Control Unit :	170 (W) x 43.5 (H) x 227 (D) mm
	(Excluding Rubber Feet and Connectors)	(4-11/16"(W) x 1-7/16"(H) x 6-1/8"(D))
Weights :	Camera Head :	18g (0.04 lbs)
	(Including Body Cap)	
	Camera Control Unit :	1.3 kg (2.86 lbs)

Weight and dimensions indicated are approximate.  
Specifications are subject to change without notice.

## Optional Accessories

- Camera Cable GP-CA1K/2, GP-CA1K/3, GP-CA1K/38 or GP-CA1K/10
- C-mount Adaptor GP-AD22TA
- Wide Angle Lens GP-LM3TA or GP-LM7TA
- Pinhole Lens GP-LP12TA
- Tele Angle Lens GP-LM15TA or GP-LM24TA
- Camera Holder GP-AD1K

# Panasonic

Broadcast & Television Systems Company

Division of Matsushita Electric Corporation of America

## INDUSTRIAL CAMERA DIVISION

Executive Office: One Panasonic Way 4H-2, Secaucus, New Jersey 07094 (201) 392-6674

**MATSUSHITA ELECTRIC OF CANADA LIMITED**

5770 Ambler Drive, Mississauga, Ontario, L4W 2T3 Canada (905) 624-5010

**PANASONIC SALES COMPANY**

**DIVISION OF MATSUSHITA ELECTRIC OF PUERTO RICO, INC.**